

PRODUCT CODE: MP250160
ECO-FRIENDLY STANDARD FOOT

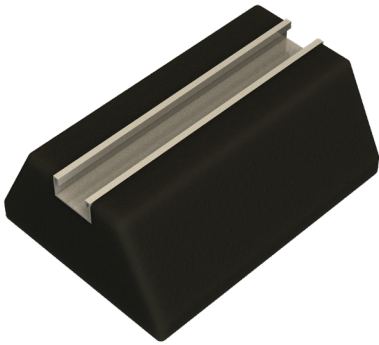

DESCRIPTION

250 x 180mm Eco-Friendly Standard Foot

FINISH

Foot: Black / Channel: Pre-Galvanised

MATERIAL

Foot: SBR Recycled Rubber / Channel: Pre-Galvanised Steel

PACKAGING

Supplied individually

ADDITIONAL NOTES

Max. loading per foot: 160kg
Suitable for internal & external applications between -40°C to +80°C
'Bonded' 41 x 21mm channel designed for use with standard channel fixings

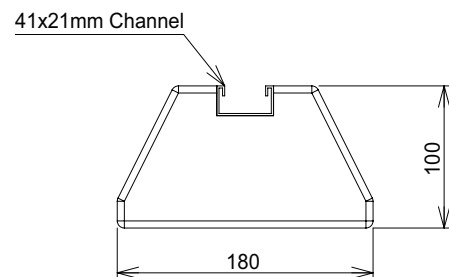
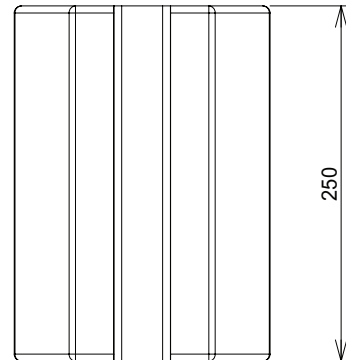
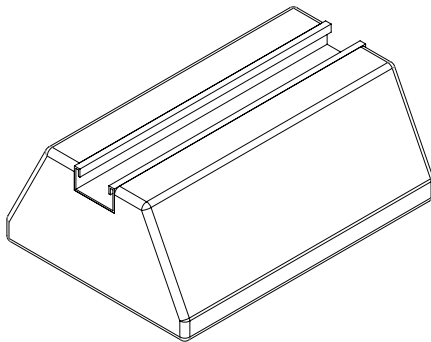

 Values are nominal and with a general tolerance $\pm 5\%$ unless otherwise specified